

datavideo®

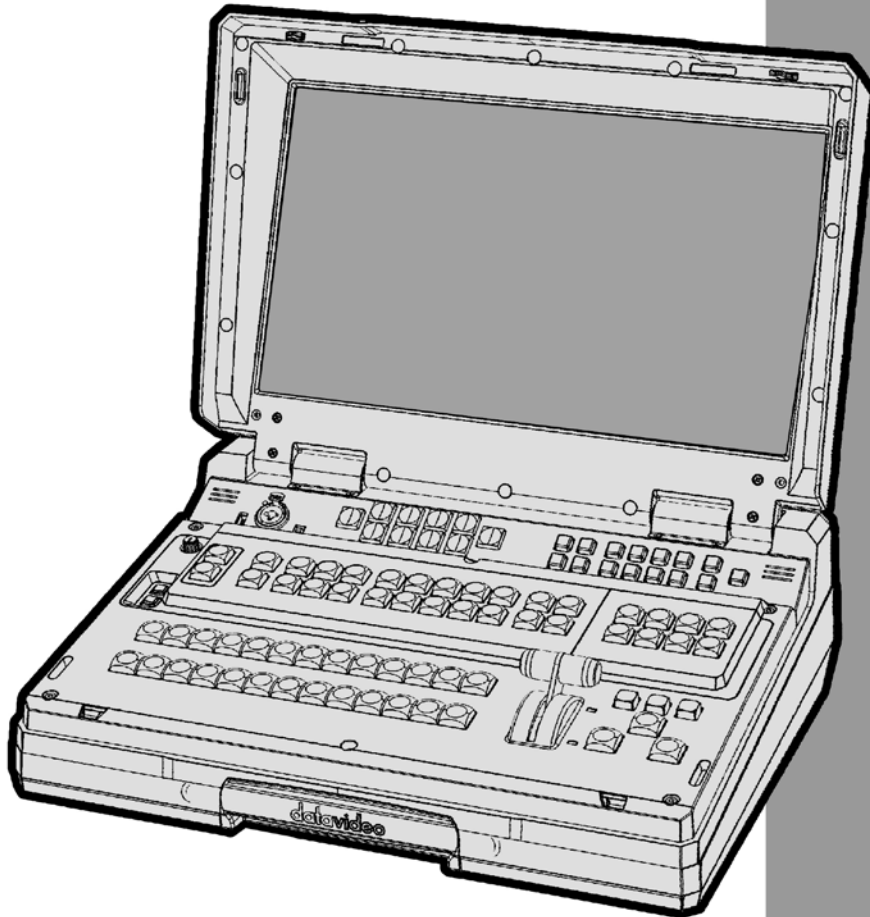

**HD/SD 12-CHANNEL
PORTABLE VIDEO STUDIO
HS-2800
Instruction Manual**

www.datavideo.com

Table of Contents

| | |
|--|-----------|
| WARNINGS AND PRECAUTIONS | 4 |
| WARRANTY | 5 |
| STANDARD WARRANTY | 5 |
| TWO YEAR WARRANTY | 5 |
| DISPOSAL | 5 |
| 1. OVERVIEW | 6 |
| 1.1 FEATURES | 6 |
| 2. CONNECTIONS & CONTROLS | 7 |
| 2.1 KEYBOARD | 7 |
| 2.2 REAR PANEL | 11 |
| 3. INTERCOM & MONITOR CONTROL PANEL | 14 |
| 3.1 INTERCOM FUNCTION | 14 |
| 3.2 MONITOR FUNCTION | 15 |
| 4. MENU OPTIONS | 16 |
| 4.1 MAIN MENU | 16 |
| 4.1.1 MAIN ADJUST | 17 |
| 4.1.2 COLOR | 17 |
| 4.1.3 Information | 17 |
| 4.1.4 Special Function | 17 |
| 4.1.5 Factory Reset | 18 |
| 4.2 MONITOR FIRMWARE UPDATE PROCEDURE | 18 |
| 5. TRANSITION EFFECTS | 19 |
| TRANSITION CONFIRMATION | 19 |
| 6. LOGO 1, LOGO 2, CLOCK AND TIMER | 20 |
| 7. PIP1, PIP2, DSK1 AND DSK2 | 21 |
| 8. FRAME STORE, AUX AND AUDIO LEVEL | 22 |
| FS – FRAME STORE BUTTON | 22 |
| HOW TO CHOOSE LIVE VIDEO INPUT OR FRAME STORE | 22 |
| AUX SOURCE SELECTION | 22 |
| AUDIO LEVEL | 22 |
| 9. SETTING SDI EMBEDDED AUDIO | 23 |
| 10. MENU OPTIONS | 24 |
| 11. HS-2800 VIDEO LAYERS | 28 |
| 11.1 PICTURE IN PICTURE FUNCTION | 29 |
| 11.2 DSK FUNCTION (CG / LUMA KEY) | 30 |

| | |
|---|-----------|
| 12. DE-EMBEDDING SDI OR HDMI AUDIO | 31 |
| 13. CALIBRATING THE T-BAR..... | 32 |
| 14. LOGOS SETUP..... | 33 |
| 14.1 STATIC LOGOS..... | 33 |
| 14.2 DYNAMIC LOGO..... | 33 |
| 15. TALLY CONNECTOR PIN ASSIGNMENT | 35 |
| 16. AUDIO DELAY | 36 |
| 16.1 SETTING THE AUDIO DELAY | 36 |
| 17. GPI / GPO CONNECTIONS..... | 37 |
| 18. SPECIFICATIONS | 38 |
| 18.1 HS-2800 SPECIFICATIONS | 38 |
| 18.2 ITC-150 (INTERCOM) SPECIFICATIONS..... | 39 |
| 18.3 ITC-100SL SPECIFICATIONS..... | 39 |
| 18.4 TLM-170H SPECIFICATIONS | 39 |
| SERVICE AND SUPPORT..... | 40 |

Disclaimer of Product & Services

The information offered in this instruction manual is intended as a guide only. At all times, Datavideo Technologies will try to give correct, complete and suitable information. However, Datavideo Technologies cannot exclude that some information in this manual, from time to time, may not be correct or may be incomplete. This manual may contain typing errors, omissions or incorrect information. Datavideo Technologies always recommend that you double check the information in this document for accuracy before making any purchase decision or using the product. Datavideo Technologies is not responsible for any omissions or errors, or for any subsequent loss or damage caused by using the information contained within this manual. Further advice on the content of this manual or on the product can be obtained by contacting your local Datavideo Office or dealer.

Warnings and Precautions

1. Read all of these warnings and save them for later reference.
2. Follow all warnings and instructions marked on this unit.
3. Unplug this unit from the wall outlet before cleaning. Do not use liquid or aerosol cleaners. Use a damp cloth for cleaning.
4. Do not use this unit in or near water.
5. Do not place this unit on an unstable cart, stand, or table. The unit may fall, causing serious damage.
6. Slots and openings on the cabinet top, back, and bottom are provided for ventilation. To ensure safe and reliable operation of this unit, and to protect it from overheating, do not block or cover these openings. Do not place this unit on a bed, sofa, rug, or similar surface, as the ventilation openings on the bottom of the cabinet will be blocked. This unit should never be placed near or over a heat register or radiator. This unit should not be placed in a built-in installation unless proper ventilation is provided.
7. This product should only be operated from the type of power source indicated on the marking label of the AC adapter. If you are not sure of the type of power available, consult your Datavideo dealer or your local power company.
8. Do not allow anything to rest on the power cord. Do not locate this unit where the power cord will be walked on, rolled over, or otherwise stressed.
9. If an extension cord must be used with this unit, make sure that the total of the ampere ratings on the products plugged into the extension cord do not exceed the extension cord's rating.
10. Make sure that the total amperes of all the units that are plugged into a single wall outlet do not exceed 15 amperes.
11. Never push objects of any kind into this unit through the cabinet ventilation slots, as they may touch dangerous voltage points or short out parts that could result in risk of fire or electric shock. Never spill liquid of any kind onto or into this unit.
12. Except as specifically explained elsewhere in this manual, do not attempt to service this product yourself. Opening or removing covers that are marked "Do Not Remove" may expose you to dangerous voltage points or other risks, and will void your warranty. Refer all service issues to qualified service personnel.
13. Unplug this product from the wall outlet and refer to qualified service personnel under the following conditions:
 - a. When the power cord is damaged or frayed;
 - b. When liquid has spilled into the unit;
 - c. When the product has been exposed to rain or water;
 - d. When the product does not operate normally under normal operating conditions. Adjust only those controls that are covered by the operating instructions in this manual; improper adjustment of other controls may result in damage to the unit and may often require extensive work by a qualified technician to restore the unit to normal operation;
 - e. When the product has been dropped or the cabinet has been damaged;
 - f. When the product exhibits a distinct change in performance, indicating a need for service.

Warranty

Standard Warranty

- Datavideo equipment is guaranteed against any manufacturing defects for one year from the date of purchase.
- The original purchase invoice or other documentary evidence should be supplied at the time of any request for repair under warranty.
- Damage caused by accident, misuse, unauthorized repairs, sand, grit or water is not covered by this warranty.
- All mail or transportation costs including insurance are at the expense of the owner.
- All other claims of any nature are not covered.
- Cables & batteries are not covered under warranty.
- Warranty only valid within the country or region of purchase.
- Your statutory rights are not affected.

Two Year Warranty

- All Datavideo products purchased after 01-Oct.-2008 qualify for a free one year extension to the standard Warranty, providing the product is registered with Datavideo within 30 days of purchase. For information on how to register please visit www.datavideo.com or contact your local Datavideo office or authorized Distributors
- Certain parts with limited lifetime expectancy such as LCD Panels, DVD Drives, Hard Drives are only covered for the first 10,000 hours, or 1 year (whichever comes first).

Any second year warranty claims must be made to your local Datavideo office or one of its authorized Distributors before the extended warranty expires.

Disposal

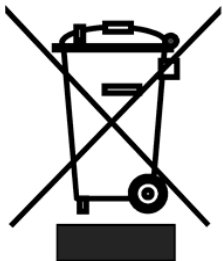

For EU Customers only - WEEE Marking.

This symbol on the product indicates that it will not be treated as household waste. It must be handed over to the applicable take-back scheme for the recycling of electrical and electronic equipment. For more detailed information about the recycling of this product, please contact your local Datavideo office.

1. Overview

The HS-2800 is an 8 channel 10-bit 1920 x 1080i & cost-effective, broadcast-quality mobile hand carry switcher. Featuring 8 digital, it is designed for live events and TV programs that need to blend a variety of video and audio sources. HS-2800 is light weight, portable and powerful features for mobile switcher solution.

As a complete AV package, the HS-2800 HD mobile studio enables users to switch seamlessly between video and audio sources and blend high-quality digital content on the fly.

Advanced features include a 17.3-inch multi-image video monitor which displays multiple sources, as well as preview and program.

The system is equipped with an eight way intercom system and is supplied with four belt packs for effective communication between the whole production crew.

The HS-2800 is ideal for TV and video professionals working in outside broadcast or temporary video studios, such as theatres or conference centres. The HS2800 is also a great value solution for the worship, education and AV market.

1.1 Features

Supports 8 HD or SD Inputs in a variety of configurations:

- **HD Mode**
 - 8 HD-SDI
 - 6 HD-SDI + 2 HDMI
- **SD Mode**
 - 8 SD-SDI
 - 6 SDI +2 HDMI
- **2 SDI Outputs assignable to AUX, Program (PGM), Preview (PVW) or PGM clean - Built-in SD down-scaler on CH-2, CH3 SDI output**
- **1 HDMI outputs for multi view monitoring**
- **Audio I/O**
 - Input: 4 analogue balanced XLR
 - Output: 2 analogue balanced XLR. Supports embedded audio SDI output from 4-CH XLR Audio input
- **Two DSK, supports Key and Fill**
- **Cut, Mix and Wipe with borders**
- **Clock on screen**
- **Countdown counter on multi screen**
- **Two PIP displays with user-defined borders**
- **Tally, GPI interface and RJ45 for firmware upgrade**
- **DC 12V operation voltage, available for mobile use**

2. Connections & Controls

2.1 Keyboard

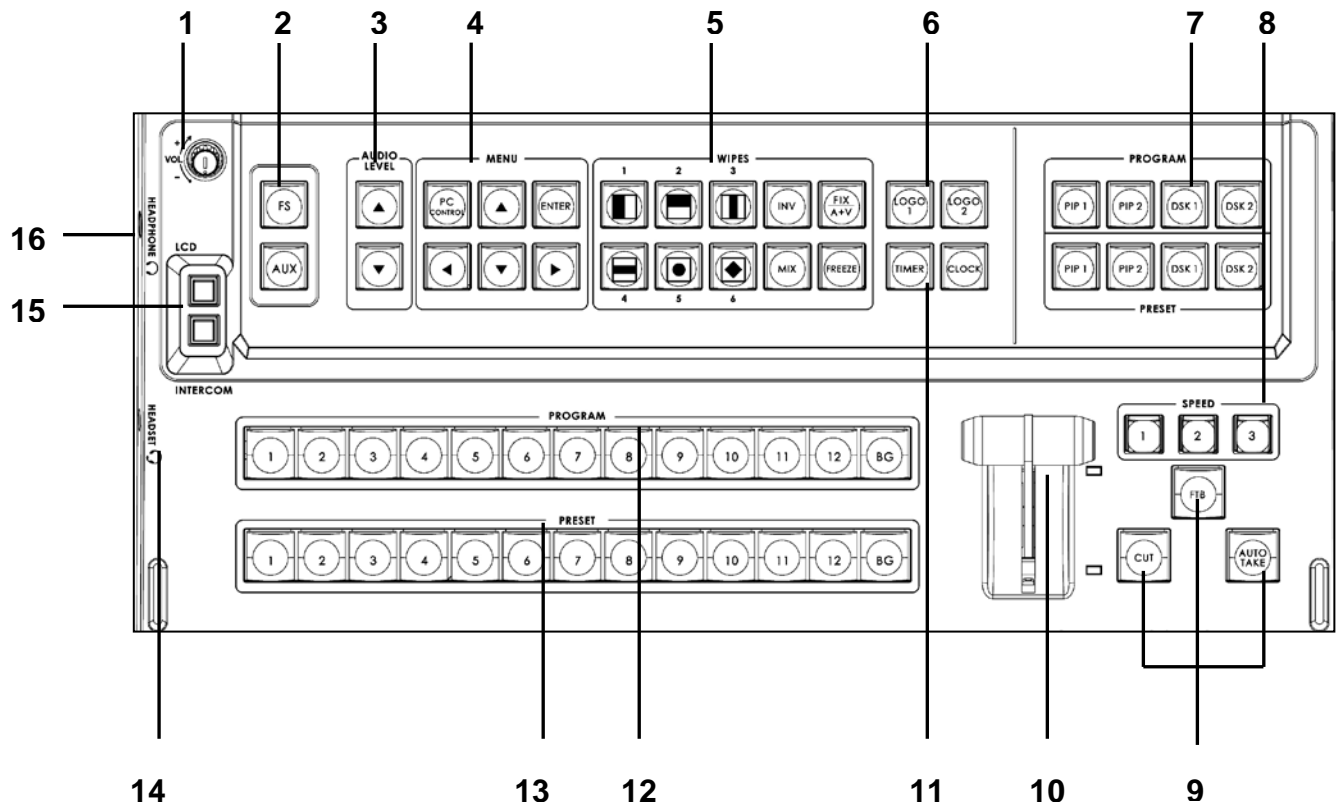

9. Headphone Volume Control

10. FS & AUX

11. AUDIO LEVEL

12. MENU

13. WIPES

14. LOGO1 & LOGO2

15. PROGRAM & PRESET

16. SPEED

1. CUT / FTB / AUTO TAKE

2. T-BAR

3. TIME & CLOCK

4. PROGRAM

5. PRESET

6. Headset

7. LCD / INTERCOM

8. Headphone

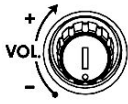

1. Headphone Volume Control

Control Headphone or Headset volume level.

Use the Headphone section to accurately monitor any of the sources (LCD or INTERCOM).

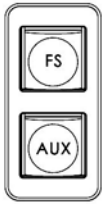

2. FS & AUX

FS

Load frame by PC remote control tool (SEConfig) to RESET (Ch1~12), and then push FS key to take.

FS button is designed to perform Frame Still=Frame Store feature. A picture that can be used as background in a live video.

To set the FS, first press and hold the FS button ⇒ then the CH buttons, 1~12 (preset box) will turn RED ⇒ pick the desire CH which user wants to have a background picture on.

AUX

There are three SDI outputs at the rear of HS-2800 and one of them can be assigned by the user to be AUX-out in order to have a clean source (the video input signal which only bypassing the HS-2800 to the recorder, without any further effects on HS-2800, for effects on a, say a PC.)

The AUX feature can be set under Manual Setting ⇒ Output Mode ⇒ assign one of the three outputs as AUX. Then, under AUX Setting, user can pick the preferred type of video source from one of the connected camera.

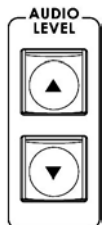

3. AUDIO LEVEL

Set the control audio levels on, press PRESET and then press AUDIO LEVEL Button for Main audio output mix.

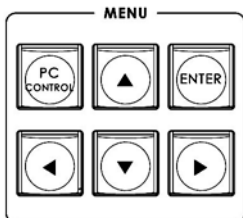

4. MENU

PC Control button is for PC remote control.

Press the up, down, left, right arrow button move to another control, and ENTER button to confirm the setting.

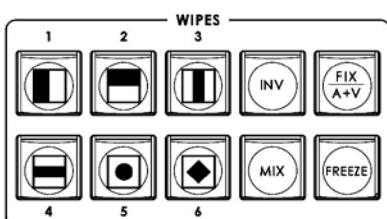

5. WIPES

Wipe with border 6+2 options (changeable)



6. LOGO1 & LOGO2

Select SE-2000 Logo1, Logo2 Functions on the screen.

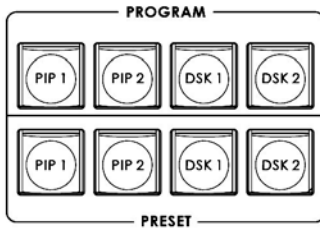

7. PROGR & PRESET

Picture In Picture can be set up in one of four preset positions, or manually moved to any position on the screen.

It is possible to overlay titles from external signal in 2 ways, i.e. via Luma Keying or via Video + a-channel. The input signals used for the titles must be the same format as the basic output mode (HD or SD). It is prohibited to apply SD titles signal when the HD is the basic format.

It is necessary to meet the following condition to realize 2 DSK channels:
 DSK1 Preview DSK1 Program (titles)
 DSK2 Preview DSK2 Program(titles)

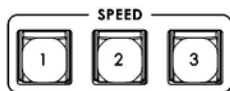

8. SPEED

Selectable of three different speeds for transition effect.

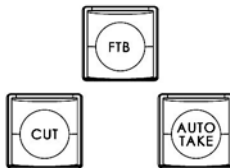

9. CUT, FTB & AUTO TAKE

CUT

Change the main/sub source immediately.

FTB

Fade to Black is performed upon FTB button stroke only in the Program Channel. The Button is lights with red color in this case.

The previously pressed button of a signal source for Program Line stays with light on.

There is FTB indication multi screen nearby the Program window.
 A repeated button stroke will escape the mode.

When the mode is active, there is Black Field in the Program, but signal switching is still functional, i.e. it is possible to replace the signal at the Program output, and there will be a selected source when the FTB is deactivated.

AUTO TAKE

Take the effect by auto speed.

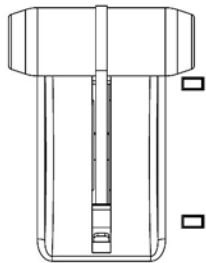

10. T-Bar

The T-Bar is used to carry out a manual transition such as a wipe, fade, mix or key. When it has travelled as far as it can go the transition is complete.

For more information, see **Calibrating the T-bar**.

If you fail to calibrate, the T-Bar may cause incorrect results.



11. TIME & CLOCK

Select HS-2800 TIMER or CLOCK Functions on the screen.



12. PROGRAM

Used to select which of the 12 video input channels or background or color bar is sent to the PROGRAM video output.



13. PRESET

Used to select which of the 12 video input channels or background or color bar will be transitioned to or used as a PRESET source in an effect.



14. Headphone Socket (HS-2000L or Monitor)

¼ "/ 6.3mm Stereo Headphone Socket for conventional headphones.



15. LCD / INTERCOM

Select Headphone & speaker audio source from LCD or INTERCOM.



16. Headphone Socket

¼ "/ 6.3mm Stereo Headphone Socket for conventional headphones.

2.2 Rear Panel

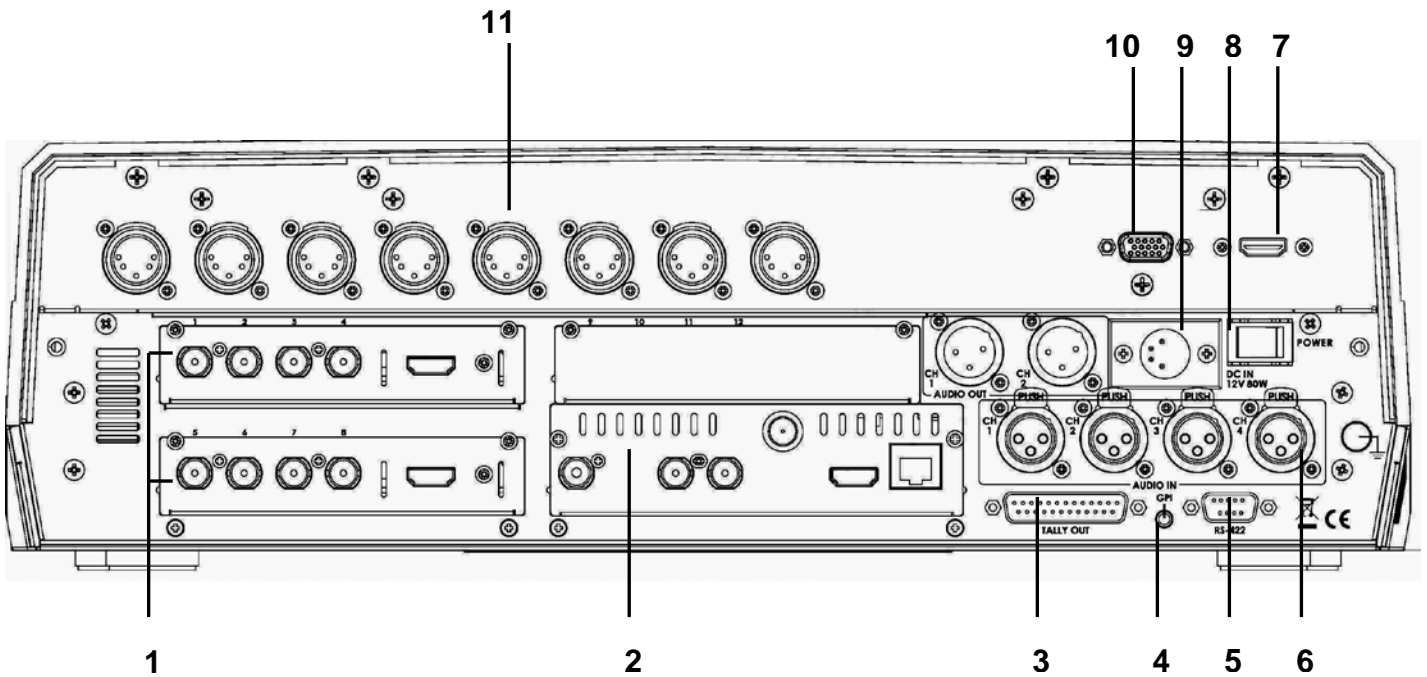

1. HD- SDI IN / HDMI IN (12CH)
2. HD- SDI OUT / HDMI OUT / REMOTE CONTROL / CONSOLE
3. TALLY OUT
4. GPI
5. RS-422
6. AUDIO IN
7. MONITOR HDMI IN
8. POWER SWITCH
9. DC IN
10. MONITOR F/W Upgrade
11. TO BELTPACK

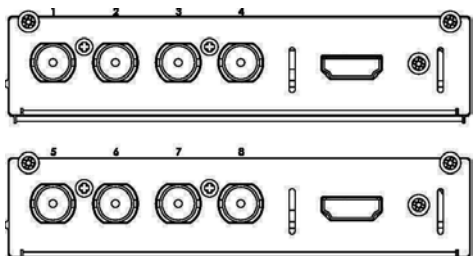

1. HD- SDI IN / HDMI IN

The system consists of 3 input modules. Each module has 4 BNC connectors and 1 HDMI connector.

There are 12 inputs altogether; part of them can be reconfigured. The maximum number of inputs for a certain input format: 12 HD SDI, 12 SD SDI, 3 HDMI.

Considering the above, it is possible to obtain the following combinations, for example 10 HD SDI + 2 HDMI, or 9HD SDI+ 3 HDMI.

Besides, we reserve a possibility to switch signal from non-volatile memory instead of 1 input in each input module, i.e. every input has an alternative to the HD SDI signal.

IN 3 is for flash static pictures, and IN 4 is to HDMI; All the video/audio input signals will be synchronized.

The HS-2800 has 2 modes HD- SDI IN (8CH or 12CH), if you want upgrade 8CH to 12CH, please re-install the HS-2800 firmware after the board upgrade otherwise the new board will not be recognizable by the main board.

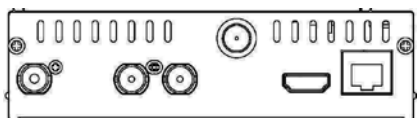

2. HD SD- SDI OUT / HDMI OUT / REMOTE CONTROL

There are

One BNC : REF IN

Two BNC output connectors: SDI Outputs

One BNC : REF LOOP

1 HDMI: Multi screen

RJ45: Remote Controls & Firmware Upgrade.

It is possible to assign one of following signals to OUT1, OUT2, OUT 3:

1. Program output
2. Preview output
3. Program output without logo
4. Program output without logo and DSK subtitles
5. Aux output of a selected video input channel

It is possible to assign OUT2, 3 to Signal from HD to SD downscaler. It can be available at one output (Output2, 3) only and this is for Program out only.

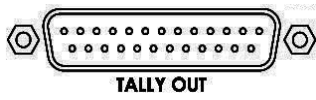

3. TALLY OUT

The HS-2800 has Tally Output port, This port provides bi-colour tally information to a number of other Datavideo products, such as the ITC-100 8 Channel Talkback, TLM-404 LCD Monitor.



4. GPI

The GPI socket can be used for simple external control.



5. RS-422

Feature Coming Soon

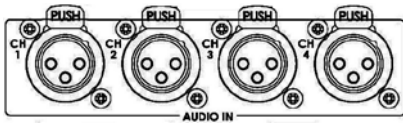

6. AUDIO IN

Supports four channels XLR Balanced Audio Input.



7. MONITOR HDMI IN

The HS-2800 provides a useful connection for confidence monitoring of HDMI sources on location.

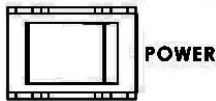

8. POWER SWITCH

Switches the power On / Off.

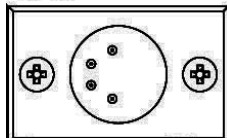

9. DC IN

Connect the supplied 12V PSU to this DC IN socket. The connection can be secured by screwing the outer fastening ring of the DC In plug to the socket.

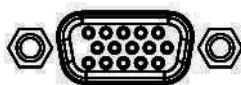

10. MONITOR F/W Upgrade

Socket is for monitor F/W upgrade.



11. TO BELTPACK (For Intercom)

Channel Input / Output XLR Sockets

Each of the 8 channels has an XLR connector that carries bi-directional signals between the ITC-150 and ITC-100SL. All connections are contained within one cable.

3. Intercom & Monitor Control Panel

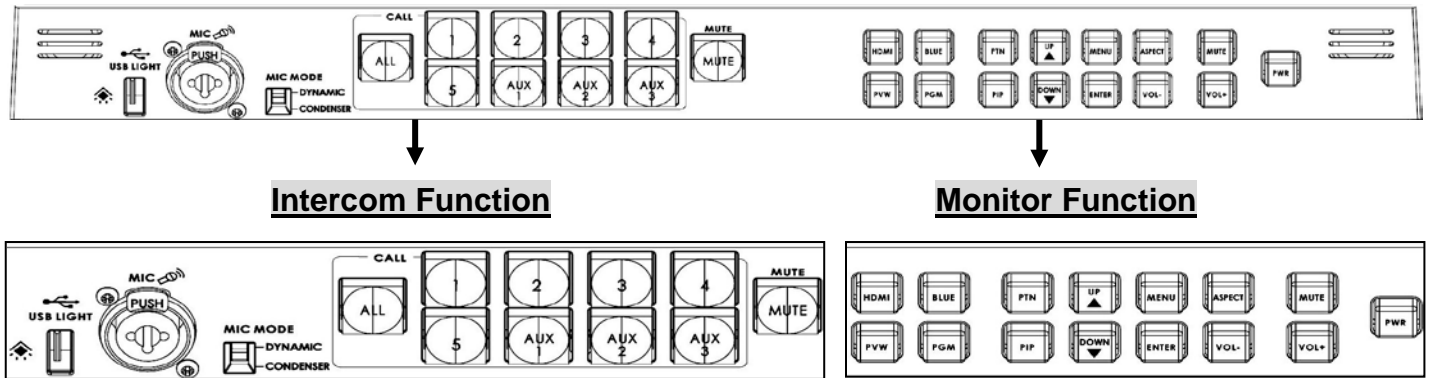

3.1 Intercom Function



USB Port

USB port for LED power supply.

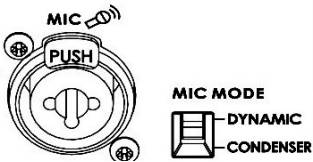

XLR Microphone Socket

Combined XLR

XLR / 1/4" (6.3mm) Jack Microphone Input for either a Condenser or Dynamic Gooseneck Microphone.

XLR supports Condenser Microphones / 1/4" (6.3mm) Jack supports Dynamic Gooseneck Microphone.



ALL Button

Opens communication with all channels. All channels will hear communication from the operator, or from any other channel using the **TALK** button.

Channel Buttons 1~8

Opens communication with individual channels. More than 1 channel can be active at any given time, active channels are illuminated red.

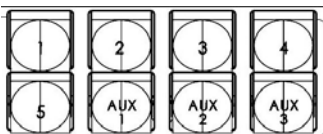

All active channels will hear any communication from the operator or from any other active channel.

The buttons will also indicate if any channel is paging, the paging channel will flash in orange until the page is answered.

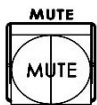

MUTE Button

Mutes all communication from the base station or any channel.

3.2 Monitor Function

HDMI, PREVIEW, PROGRAM

Select the type of input you are using - HDMI, PREVIEW, PROGRAM.

The active input will be indicated by a red LED on the Source Button.

When you push the "HDMI" button, you select the 17.3" display from the HDMI source input of Rear Panel; it is a full screen display.

When you push the "PREVIEW" button, then you go back to show multi-view from the other SDI inputs. So you can switch back & forth between HDMI & Preview.

BLUE

Press this button to eliminate the red and green component of input signals. Only the blue component of an input is displayed on the screen.

PATTERN

Press the PATTERN Key to activate the colour bar.

PIP

The PIP Feature Setting Menu allows you to adjust the appearance of the picture in picture. The position, size, main source and sub source can be set in the menus.

Menu Navigation Buttons

Display and navigate the set up menus - See Menu Options for more details

Down Button also switches the Safe Area Mask On / Off

UP Button also switches the 4:3 Mask On / Off - (only available in 16:10 modes)

Mute Button

Mutes the audio from the internal speakers or headphone socket.

Volume Control & Audio Meter

Adjusts the speaker / headphone volume up / down.

Aspect Ratio Button

Sets the Aspect Ratio to 16:10 / 4:3

PWR

Switches the TLM-170 Power ON / OFF.

4. Menu Options

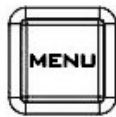

The HS-2800 Monitor set up via on screen menus. To display the on screen menu press the MENU button.

The menus are navigated using the Up / Down buttons.



Press Enter button to enter or exit the setting mode.

4.1 MAIN MENU

| Main Options | Sub Options | Parameters | Parameters | |
|------------------|-------------------|------------------------|------------|--|
| MAIN ADJUST | BRIGHTNESS | 0~100 | | |
| | CONTRAST | 0~100 | | |
| | SHARPNESS | 0~100 | | |
| | SATURATION | 0~100 | | |
| | TINT | 0~100 | | |
| | BACK LIGHT | 0~100 | | |
| | NR | HIGH / MID / LOW / OFF | | |
| | MPEG NR | HIGH / LOW / OFF | | |
| | VOLUME | 0~100 | | |
| | EXIT | | | |
| COLOR Adjust | 7500 | | | |
| | 9300 | | | |
| | 6500 | | | |
| | USER COLOR | RED | 0~100 | |
| | | GREEN | 0~100 | |
| BLUE | | 0~100 | | |
| EXIT | | | | |
| SCAN SETTING | UNDER SCAN | | | |
| | OVER SCAN | | | |
| INFORMATION | H. FREQUENCY | | | |
| | V. FREQUENCY | | | |
| | RESOLUTION | | | |
| | VER. | | | |
| LANGUAGE | English [default] | | | |
| | Francis | | | |
| | Deutsch | | | |
| | Español | | | |
| | Italiano | | | |
| | Dutch | | | |
| | Português | | | |
| | Russian | | | |
| EXIT | | | | |
| SPECIAL FUNCTION | OSD TIMEOUT | 5-120 SEC | | |
| | FRAME RATIO | 90 / 80 / OFF | | |
| | 4:3 MARK LINE | ON / OFF | | |
| | CENTRAL MARK | ON / OFF | | |
| | CINEMA ZONE MARK | ON / OFF | | |
| | AUDIO CHANNEL L* | 1/2/3/4 | | |
| | AUDIO CHANNEL R* | 1/2/3/4 | | |

| | |
|---------------|------|
| | EXIT |
| FACTORY RESET | |
| EXIT | |

* Selectable on PGM only; external HDMI and MV are allowed on 1 and 2 ONLY

4.1.1 MAIN ADJUST

The first menu to be displayed is the MAIN ADJUST Menu.

To access the MAIN ADJUST Menu press enter, the Brightness setting will be highlighted.

To adjust the Brightness press Enter again. Use the Up / Down buttons to change the setting and then press Enter to store the new value and return to the main menu.

To select a different setting (Brightness, Contrast, Saturation, Sharpness, TINT), use the Up / Down buttons. Follow the same procedure to set other values.

4.1.2 COLOR

To access the menu press enter so that Color Adjust option is highlighted

To access the option for the selected color setting, press enter again.

Use the Up / Down buttons to navigate the available color settings.

You can choose:

- 7500
- 9300
- 6500
- USER COLOR

4.1.3 Information

The System Information Menu displays Horizontal Frequency, Vertical Frequency, Resolution and the Firmware Version of the monitor.

Once selected, the information will be displayed as follows:

You will see:

| | |
|--------------|------------|
| H. FREQUENCY | 33.7KHZ |
| V. FREQUENCY | 60.0HZ |
| RESOLUTION | 1920X1080I |
| VER. | 0.11 |

4.1.4 Special Function

The Special Function Menu has settings for the OSD TIMEOUT, Frame Ratio, 4:3 MARK LINE, Central Mark, Cinema Zone Mark and Audio Channel L & R.

To access the options for the selected setting press enter again, so that the option is highlighted

Use the Up / Down buttons to navigate the available options.

You can choose:

| | |
|--------------------|---------------|
| OSD TIMEOUT | 5-120 SEC |
| FRAME RATIO | 90 / 80 / OFF |

| | |
|-------------------------|----------|
| 4:3 MARK LINE | ON / OFF |
| CENTRAL MARK | ON / OFF |
| CINEMA ZONE MARK | ON / OFF |
| AUDIO CHANNEL L* | 1/2/3/4 |

4.1.5 Factory Reset

The monitor menu offers a Factory Reset option, which will return all the settings of the monitor to the factory defaults

To reset the monitor press the MENU button and then use the UP / Down button to navigate to FACTORY RESET option. Press ENTER again to reset the monitor. After a few seconds the monitor will be reset.

4.2 Monitor firmware update procedure

From time to time Datavideo may release new firmware to either add new features or to fix reported bugs in the current HS-2800 Monitor firmware. Customers can update the firmware themselves if they wish or they can contact their local dealer or reseller for assistance should they prefer this method.

This page describes the firmware update process and it should take **approximately 15 minutes total time to complete**.

As well as a working HS-2800 Monitor you will need:

- The latest firmware update for the **HS-2800 Monitor**.
This firmware file can be obtained from your local Datavideo office or dealer.
- USB 2.0 pen drive 128MB or larger with a USB A connector.

Once started **the update process should not be interrupted in any way** as this could result in a non-responsive unit.

How to update the firmware

1. Unzip / extract the supplied zipped archive or rar folder.
2. Wipe the contents of the USB 2.0 pen drive so it is empty.
3. Transfer / copy the unzipped / extracted file to the USB 2.0 pen drive; make sure the file name is renamed to MSTFLASH.bin.
4. Plug the USB 2.0 pen drive into the USB 2.0 port labelled MONITOR F/W UPGRADE on the front of the monitor button panel.
5. Reboot **HS-2800** and the update will be automatically in progress.
6. The **HS-2800 Monitor** will reboot itself at the end of the process.

Once started **the update process should not be interrupted in any way** as this could result in a non-responsive unit.

5. Transition Effects

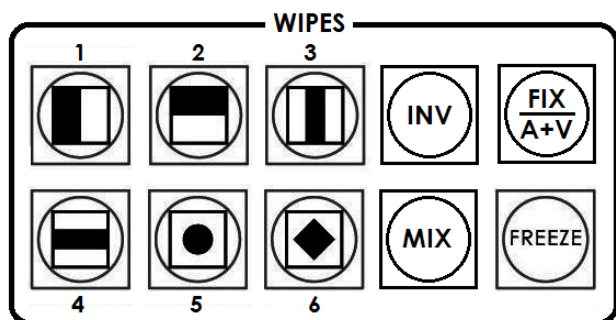

The SE-2800 features six user defined wipe buttons, an A/B dissolve or **MIX** button, an **INV** or Invert wipes button and a **FREEZE** button.

All wipes can have an optional colour border applied. The wipe border width and colour are chosen within the menu system.

Transitions can be performed manually using the T-Bar or automatically by using the **SPEED** and **AUTO TAKE** buttons.

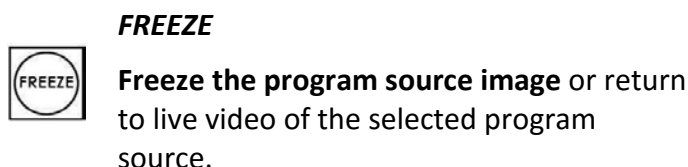
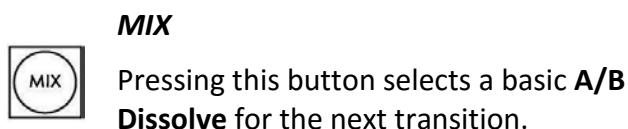
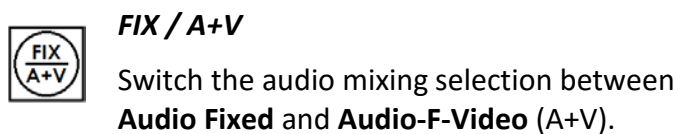
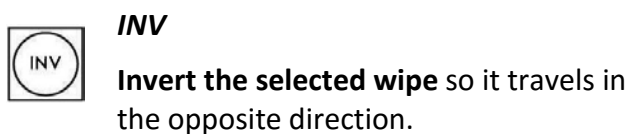
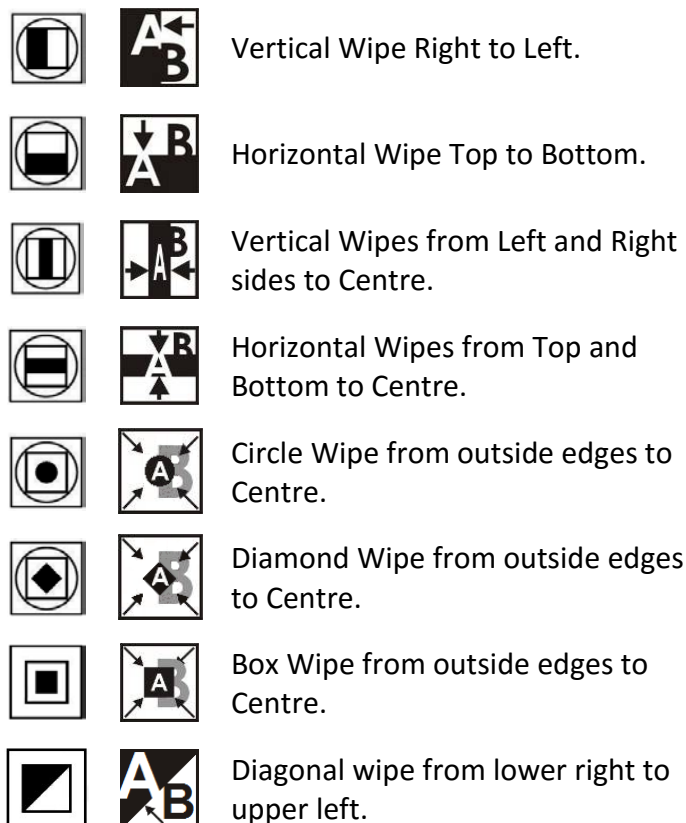
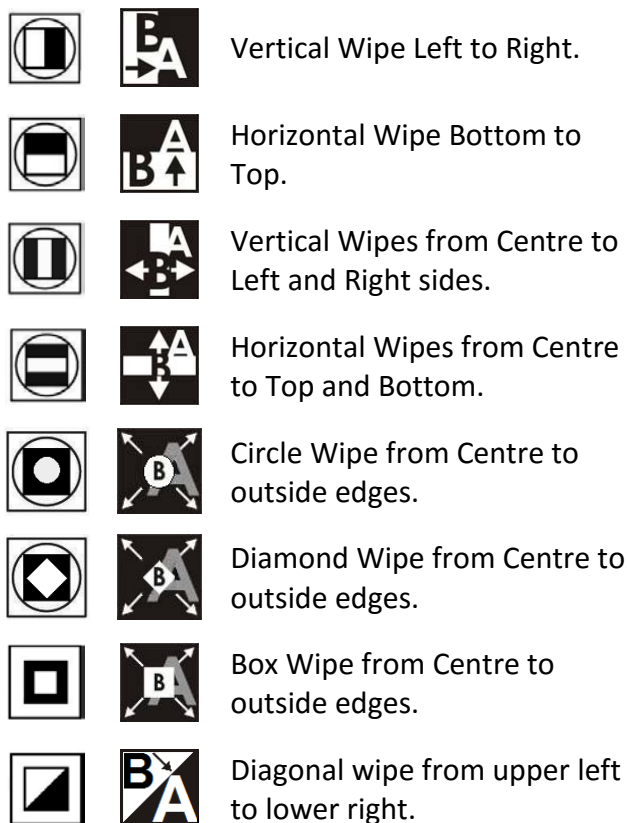

Transition Confirmation

The selected transition is highlighted in the status area of the HDMI multi-view output. When the **INV** button is pressed the six wipe icons change to their opposite direction icon.

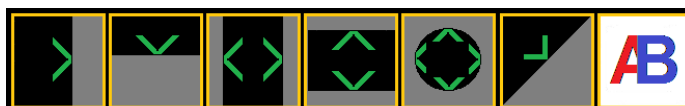

6. LOGO 1, LOGO 2, CLOCK and TIMER

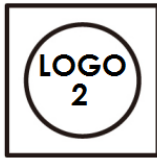
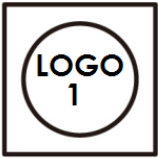

The SE-2800 has the ability to store six static logos and one dynamic logo. The logo files are transferred to the SE-2800 from a Windows PC using the Ethernet connection and the supplied **SEConfig software**.

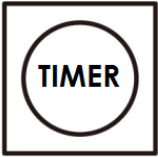

LOGO 1

The LOGO 1 and LOGO 2 buttons are used to display pre-selected logos on the SE-2800 Preset and Program outputs. When the button is active the selected logo is shown. These logos are selected from the switcher's memory and positioned using a menu option.

LOGO 2 or CLOCK

The user cannot display LOGO 2 and CLOCK at the same time. Instead use LOGO 1 and CLOCK together or use LOGO 1 and LOGO 2 together.

The clock time can be synchronised with a computer or set manually using a menu option. The colour and font used in the clock digits can be changed using the supplied **SEConfig software**.

TIMER

In some mixing or switching applications it is useful to have a countdown timer. It could be that the input is a pre-recorded video clip and you need to know when to be ready to switch away from it.

This countdown timer function is only seen in the status area of the HDMI multi-view output to the right of the normal Clock function. The timer can be selected for one input channel, several channels or all channels.

When the TIMER button is active and the user switches to a selected input channel the countdown starts on the HDMI multi-view.

The value of the countdown, in minutes and seconds (MM:SS), is set by a menu option. Whilst the countdown is in progress T-Bar operation is ignored.

When the countdown reaches zero the user can then switch or transition to another input channel. If the countdown reaches zero the switcher will not automatically change to the selected Preset source.

7. PIP1, PIP2, DSK1 and DSK2

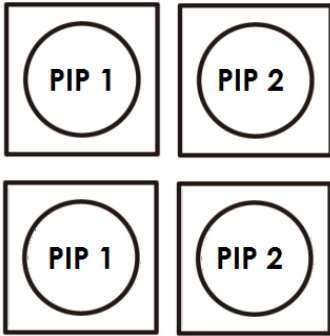

PIP Preset and PIP Program

When looking at the top right corner of the SE-2800 Control Panel / Keyboard there are four PIP keys. These are labelled Program and Preset. The upper PIP1 and PIP2 keys relate to activating Picture In Picture images on the Program outputs. The lower PIP1 and PIP2 keys relate to activating Picture In Picture images on the Multi-view or Preview outputs.

Assigning a video source input to a PIP

Using the lower PIP1 or PIP2 buttons you can assign a selected video input to the chosen PIP video layer.

- 1) First press and hold down the required PIP button on the lower row. The Preset row of input sources will light.
- 2) While still holding down the PIP button, press to select the required input from the Preset row.
- 3) The input will flash to confirm it is selected.

This selection will also be confirmed on the HDMI Multi-view, with a P1 or P2 label shown next to the selected input image.



DSK Preset and DSK Program

When looking at the top right corner of the SE-2800 Control Panel / Keyboard there are four DSK keys. These are labelled Program and Preset. The upper DSK1 and DSK2 keys relate to activating Down Stream Keying on the Program outputs. The lower DSK1 and DSK2 keys relate to activating Down Stream Keying on the Multi-view or Preview outputs.

Assigning an input to a DSK channel for keying

Using the lower DSK1 or DSK2 buttons you can assign a selected video input to the chosen DSK video layer.

1. First press and hold down the required DSK button on the lower row. The Preset row of input sources will light.
2. While still holding down the DSK button, press to select the required input from the Preset row.
3. The input will flash to confirm it is selected.

This selection will also be confirmed on the HDMI Multi-view, with a T1 or T2 label shown next to the selected input image.

8. Frame Store, AUX and Audio level

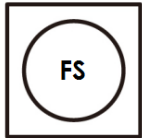

FS – Frame Store Button

The SE-2800 has eight or twelve video channels, depending on the number of inputs it has. Each of these channels has its own Frame Store, making a total of eight or twelve Frame Stores. Each of these Frame Stores can hold one still image. This still image can be called into the production by using the FS button located at the top left corner of the SE-2800 Control Panel / Keyboard. The FS button allows the user to toggle between the still image of the Frame Store or the live video input also connected to that same video channel.

How to choose live video input or Frame Store

1. First press and hold down the FS button. The Preset row of input sources will light.
2. While still holding down the FS button, press the required input on the Preset row.
3. The input button will flash to confirm the Frame Store is selected.

This selection will also be confirmed on the HDMI Multi-view, with the selected channel showing the live input or frame store image.

The contents of each Frame Store are uploaded to the SE-2800 from a PC. The supplied **SEConfig** software is used to do this.

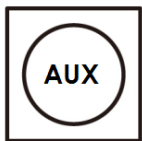

AUX Source Selection

The SE-2800 has three user defined SDI outputs, see page 9 item 15. One or all of these outputs can be set up as an auxiliary (AUX) output via a menu option. See **page 17** onwards for details.

The AUX output source can be quickly selected in the following way.

1. First press and hold down the AUX button. The Preset row of input sources will light.
2. While still holding down the AUX button, press the required input on the Preset row.
3. The input button will flash to confirm the AUX source is selected.

This selection will also be confirmed by the SD/HD-SDI Monitor supplied with these AUX images.

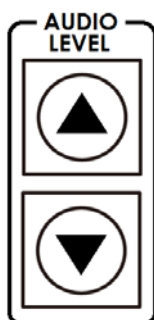

Audio Level

The SE-2800 has ability to do a basic mix/switch of analogue, SDI and HDMI embedded audio, see **page 31** for details.

The AUDIO LEVEL buttons are related to the level of the Program audio output, whether SDI embedded or analogue XLR.

9. Setting SDI Embedded Audio

Set up the HS-2800 SDI Embedded audio as shown in the diagram below. The audio signal sources are XLR Audio.

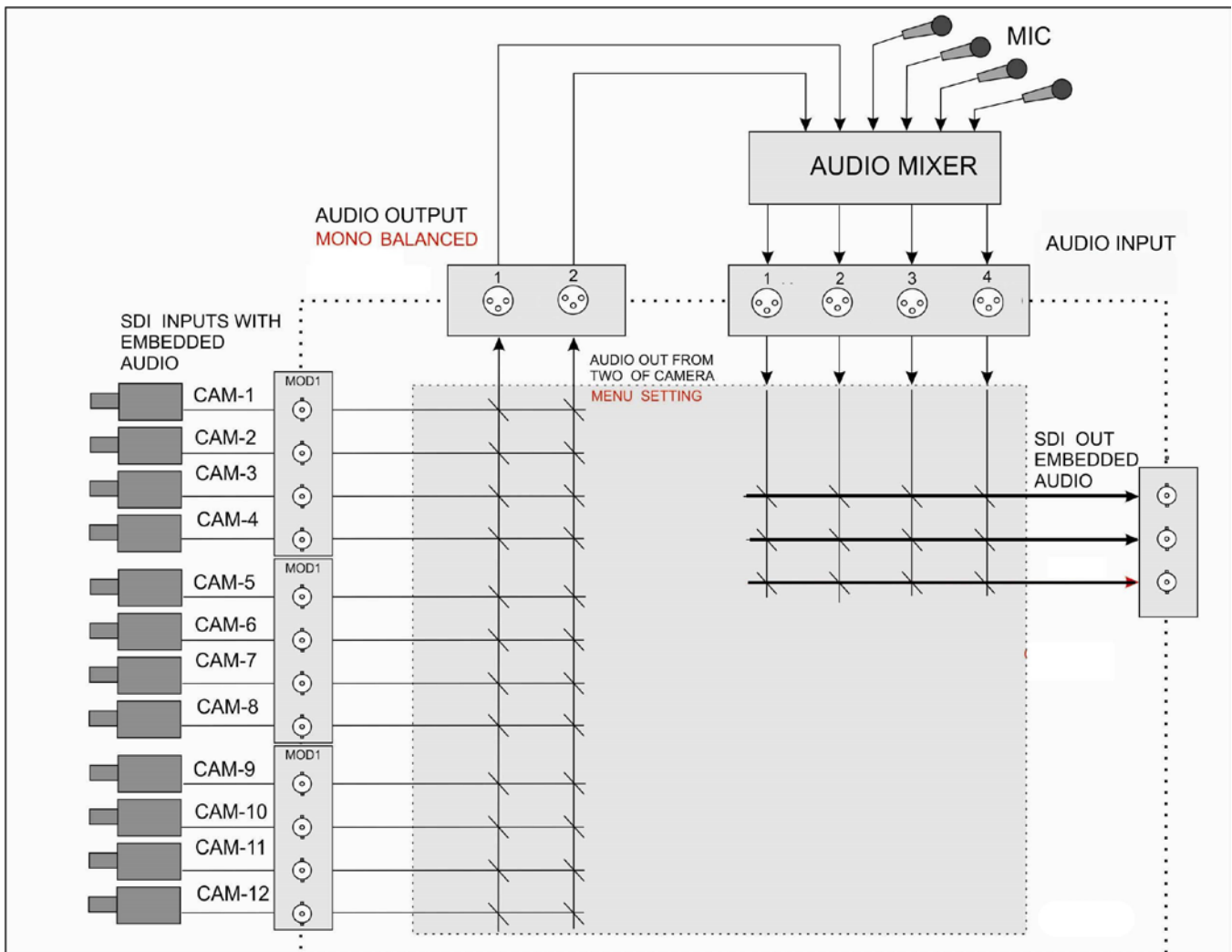

10. Menu Options

When the **ENTER** button is pressed the Main Menu list is displayed on the HDMI 1 Multi-view output.

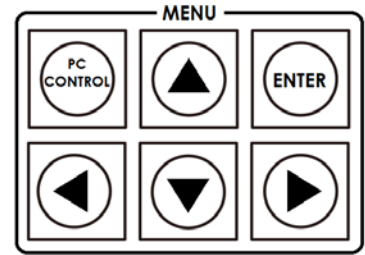

This section covers the Menu options in the order that they appear on the SE-2800 HDMI 1 Multi-view. These settings may also appear in more detail elsewhere in this instruction manual. Options may vary depending on the firmware version in use.

Once the chosen setting has been confirmed with the **ENTER** button it is stored within the switchers non-volatile memory.

| | | | |
|------------------------------------|--|---|---|
| Version Number | V.xx.xx - where xx.xx is the firmware version number | | |
| Input Video Settings | Brightness Contrast Saturation Aperture Y-C Delay Set To Nominal | Range xx to xx Range xx to xx Range xx to xx Not used in current firmware Not used in current firmware Reset to default values | |
| Inputs Standard and Format | Inputs 1,2,5,6,9 &10 Can be a choice of HD SDI* SD SDI 4:3 SD SDI 16:9 Inputs 3,7 &11 Can be a choice of HD SDI* SD SDI 4:3 SD SDI 16:9 Inputs 4,8 &12 Can be a choice of HD SDI* SD SDI 4:3 SD SDI 16:9 or HDMI* HDMI SD 4:3 HDMI SD 16:9 <i>*All HD inputs are natively 16:9 aspect.</i> | | |
| Input Audio Settings | Level Nominal | Range -60 to +60 Resets value to zero | |
| SDI Embedded Audio Set. | Inputs 1 to 12 | User choice of | Group 1,2,3 or 4 Pair 1 or 2 |
| HDMI in Embedded Audio Pair | Input 4,8 or 12 | User choice of | Group 1,2,3 or 4 |
| | | User choice of | Group 1,2,3 or 4 |

| | | | |
|--------------------------------|--|---|--|
| Outputs Emb Audio Group | Outputs 1,2 or 3 | | |
| Auto Audio Mixing Type | User choice of | X type or V type Tick selection | X type = A/B cross fade V type = Fade out A then Fade in B |
| T-Bar Audio Mixing Type | Tick selection of | Follow auto audio mixing type (use above option) By the end (clean cut or immediate audio switch) | |
| PIP Settings | Position PIP1 Size PIP1 Border PIP1 Position PIP2 Size PIP2 Border PIP2 | X-Position (Left to right) = 000 to 097 Y-Position (Lower to Upper) = 000 to 108 PIP Size = 1 (small) to 33 (large) Border Size = 0 (OFF), 1 (Thin) to 15 (Thick) Border Color = 1 to 8 (user defined colours) 1=White, 2=Yellow, 3=Cyan, 4=Green, 5=Magenta, 6=Red, 7=Blue, 8=Black | |
| LOGO Settings | Logo1 Logo2 | X-Position (Left to right) = 000 to 110 Y-Position (Lower to Upper) = 000 to 135 Selection = 1 to 8 Logo selection 1 to 7 are still image Logo 8 selection is dynamic moving image | |
| Speed Buttons Setting | Speed1 Speed2 Speed3 | Range 1 to 127 (Frames) | |
| Wipe Buttons Setting | Buttons 1 to 6 | Wipe 1 to 8 (See page 13 also) Soft Edge 0 to 4 Color 1 to 8 1=White, 2=Yellow, 3=Cyan, 4=Green, 5=Magenta, 6=Red, 7=Blue, 8=Black | |
| Outputs Mode | OUT 1 is an HD SDI only user choice of Free | Program Program Logo Free Program Logo & Titles Preview Aux | |

| | | |
|-----------------------------|---|---|
| | OUT 2 user choice of Standard & Format HD SDI SD SDI 4:3 SD SDI 16:9 Plus MODE choice of Program Program Logo Free Program Logo & Titles Free Preview Aux OUT 3 has the same user choices as OUT 2 | |
| DSK Settings | Titles 1 Titles 2 | Titles + a-CH mode (alpha channel) Luma Key mode Luma Key Level 0 (black) to 255 (white) |
| BG Color Setting | User choice of background colour from 1 to 9 1=White, 2=Yellow, 3=Cyan, 4=Green, 5=Magenta, 6=Red, 7=Blue, 8=Black, 9 = SMPTE 75% colour bars | |
| T-Bar Mode | One Way Mode Two Way Mode | = T-Bar operates transition in only one direction = T-Bar operates transition in both directions |
| 1kHz to Bars | When BG Color Setting option above = 9 1kHz tone can be ON or OFF depending on tick selection | |
| Keys Brightness | User choice of 1 to 4 Brightness of keyboard buttons, 1= Low, 4= High | |
| Keys Mode | Tick selection ON or OFF, ON=Active buttons are Red, OFF=Green is Active | |
| Audio Level is shown | Tick selection ON or OFF, ON=Audio Peak Meters shown on HDMI Multi-view | |
| Reference | External Mode Tick selection for ON or OFF Choice of HD Analog 3 Level Signal Or SD Composite PAL/NTSC H-Timing Zero to 15 | |

| | |
|---------------------------------|---|
| Aux | The value shown here relates to the selected input – See page 16 also. This setting is also related to the Outputs Mode on page 17 . |
| Factory Settings | Tick selection ON or OFF, ON= Reset all settings to their default values. |
| Clock Settings | X-Position (Left to right) = 000 to 110 Y-Position (Lower to Upper) = 000 to 135 Set Hours Set Minutes Clear Seconds |
| Multi Screen Mode | This selection relates to the HDMI outputs 1 (=W1) and 2 (=W2). A : W1 = PGM + PVW + 3 IN ; W2 = 9 IN B : W1 = PGM + PVW + 12 IN ; W2 = PGM C : W1 = PGM + PVW + 8 IN ; W2 = PGM D : W1 = PGM + PVW + 12 IN ; W2 = W1 E : W1 = PGM + PVW + 8 IN ; W2 = W1 See page 11 also. |
| GPI Settings | Input Select = Chosen input number Time Delay = In frames between 1 to 75 |
| Countdown Timer Settings | Each input can selected for Count Down ON or OFF. If Count Down is ON then the Down Counter value is set in minutes and seconds (MM:SS) - Max.= 1 Hour or 60:00, Default = 15 Seconds or 00:15 |
| Audio Associations | Input channels 1-12, Value 1-12 (used to choose an embedded audio source – see page 31 onwards for more details) |
| Multi Screen Audio | Tick selection of Program or Preview audio on the HDMI outputs. |

11. HS-2800 Video Layers

The SE-2800 is a Standard Definition or High Definition Digital Video Switcher and as well as mixing video and audio sources it has additional functions such as Picture In Picture (PIP), DSK LUMA KEY and LOGOs.

Before attempting to use the SE-2800's PIP, DSK LUMA KEY and LOGO functions it may help to first understand the order of the video layers at the SE-2800 Program (PGM) outputs.

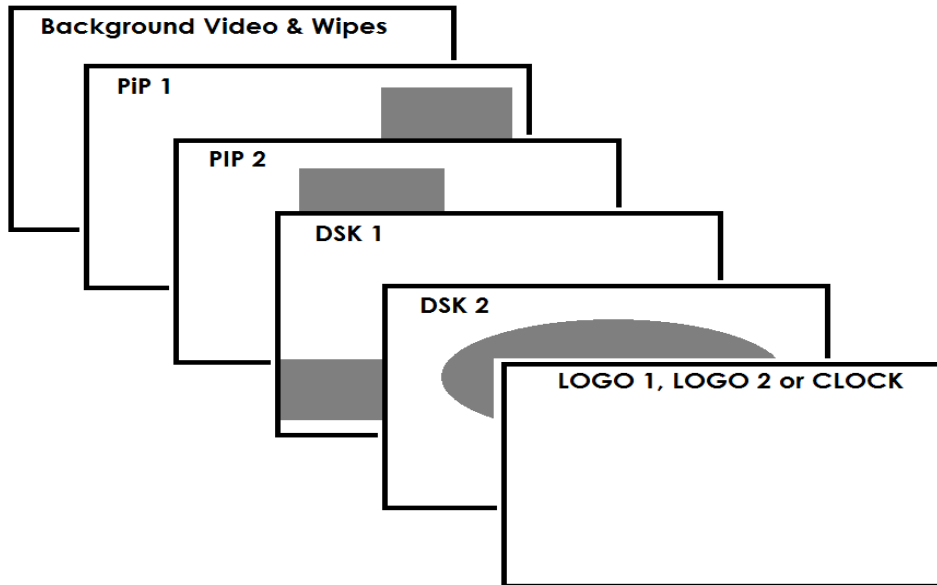

The **Background video layer** is the normal video layer when mixing and switching with the SE-2800. It occupies the whole screen area of the Program output. This layer can be hidden or part hidden by the PIP, DSK and LOGO layers in front of it.

The **PIP 1 layer** does not occupy the whole screen and is shown in front of the Background video layer when enabled. In some setups the PIP 1 image can be hidden behind the PIP 2 image. This is not a fault. Change the position or size of the PIP 1 or PIP 2 image if required.

The **PIP 2 layer** does not occupy the whole screen and is shown in front of the Background video and PIP 1 layers when enabled. In some setups the PIP 1 image can hide the PIP 2 image. Change the position or size of the PIP 2 or PIP 1 image if required.

The **DSK 1 layer** can occupy the whole screen. If set up incorrectly this layer can stop the video layers behind it from being seen properly. Re-adjust your DSK 1 settings or switch off the DSK1 function on the SE-2800 to restore the video behind it.

The **DSK 2 layer** can occupy the whole screen. If set up incorrectly this layer can stop the video layers behind it from being seen properly. Re-adjust your DSK 2 settings or switch off the DSK1 function on the SE-2800 to restore the video behind it.

The **LOGO and Clock layer** does not occupy the whole screen and all other layers are visible through it. A logo if positioned incorrectly can partially hide an important part of the video, PIP or CG LUMA KEY layers. Typically logos or station ID bugs are placed in a corner of the screen.

NB: Where possible prepare and position the upper video layer elements in advance of the live production starting to avoid them appearing on the program output incorrectly.

Most broadcast networks have guidelines and advice on the use of video, images, music, logos and on screen text so it is best to check beforehand when planning a production. Do not use copyright protected content until you have the relevant permissions. Information on royalty free video, images and music is widely available, speak to your local dealer or search for advice on the internet.

11.1 Picture in Picture function

The SE-2800 Picture in Picture function allows you to place one or two smaller PIP images over a chosen full size background image. The smaller PIP images can be set to pre-defined sizes and positioned almost anywhere within the Preview/Program screen area. These PIP windows can also have a coloured border applied, and can be brought into the production with a default PIP dissolve transition.

PIP Settings

Before trying to activate the PIP function it is best to understand how to set up or choose the right options for your production. Press the **ENTER Key** in the **MENU** area of the SE-2800 keyboard. Navigate to the **PIP Settings** option using the down arrow key. The PIP menu options provided here are:

| | | |
|---------------------|----------------------|---|
| PIP Settings | Position PIP1 | X-Position (Left to right) = 000 to 097 Y-Position (Lower to Upper) = 000 to 108 |
| | Size PIP1 | PIP Size = 1 (small) to 33 (large) |
| | Border PIP1 | Border Size = 0 (OFF), 1 (Thin) to 15 (Thick) |
| | Position PIP2 | Border Color = 1 to 8 (user defined colours) |
| | Size PIP2 | 1=Yellow, 2=Cyan, 3=Green, 4=Magenta, 5=Red, 6=Blue |
| | Border PIP2 | |

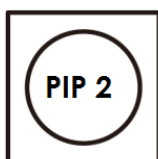
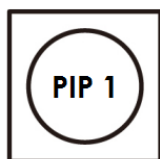

PIP Preset and PIP Program

When looking at the top right corner of the SE-2800 Control Panel / Keyboard there are four PIP keys. These are labelled Program and Preset.

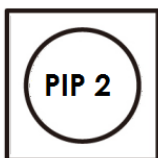
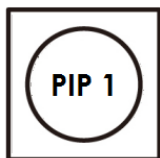

The upper PIP1 and PIP2 keys relate to activating Picture In Picture images on the Program outputs.

The lower PIP1 and PIP2 keys relate to activating Picture In Picture images on the Multi-view or Preview outputs.

Assigning a video source input to a PIP

Using the lower PIP1 or PIP2 buttons you can assign a selected video input to the chosen PIP video layer.

- 1) First press and hold down the required PIP button on the lower row. The Preset row of input sources will light.
- 2) While still holding down the PIP button, press to select the required input from the Preset row.
- 3) The input will flash to confirm it is selected.

This selection will also be confirmed on the HDMI Multi-view, with a P1 or P2 label shown next to the selected input image.

11.2 DSK function (CG / LUMA KEY)

The SE-2800 has two Down Stream Keyers (**DSK1, DSK2**). This means it is able to take a key source video input and replace the white or black parts of this image with the video from another source. If the input video carries an alpha channel it is also possible to key in this way too.

DSK Settings

Before trying to activate the DSK function it is best to understand how to set up or choose the right options for your production well in advance of the production.

Press the **ENTER Key** in the **MENU** area of the SE-2800 keyboard. Navigate to the **DSK Settings** option using the down arrow key. The DSK menu options provided here are:

| | | |
|----------------------------|--|---|
| <p>DSK Settings</p> | <p>Titles 1 (DSK1) Titles 2 (DSK2)</p> | <p>Titles + a-CH mode (alpha channel mode) Luma Key mode Luma Key Level 0 (black) to 255 (white)</p> |
|----------------------------|--|---|



DSK Preset and DSK Program

When looking at the top right corner of the SE-2800 Control Panel / Keyboard there are four DSK keys. These are labelled Program and Preset.



The upper DSK1 and DSK2 keys relate to activating Down Stream Keying on the Program outputs.

The lower DSK1 and DSK2 keys relate to activating Down Stream Keying on the Multi-view or Preview outputs.

Assigning an input to a DSK channel for keying

Using the lower DSK1 or DSK2 buttons you can assign a selected video input to the chosen DSK video layer.

1. First press and hold down the required DSK button on the lower row. The Preset row of input sources will light.
2. While still holding down the DSK button, press to select the required input from the Preset row.
3. The input will flash to confirm it is selected.

This selection will also be confirmed on the HDMI Multi-view, with a T1 or T2 label shown next to the selected input image.

12. De-embedding SDI or HDMI audio

Using the following SE-2800 menu options audio can be selected from the SDI or HDMI video inputs.

| | | | |
|------------------------------------|------------------------|----------------|---|
| SDI Embedded Audio Set. | Inputs 1 to 12 | User choice of | Group 1,2,3 or 4 Pair 1 or 2 |
| HDMI in Embedded Audio Pair | Input 4,8 or 12 | User choice of | Group 1,2,3 or 4 |

As each SDI / HD-SDI source can have up to sixteen channels of audio, and HDMI eight channels, we need to choose the audio channels with the options above and by the following reference tables.

| SDI Embedded Audio | | | |
|---------------------------|--------------------|----------------|---------------|
| Group | Stereo Pair | Channel | Number |
| Group 1 | Stereo pair 1 | left | 1 |
| | | right | 2 |
| | Stereo pair 2 | left | 3 |
| | | right | 4 |
| Group 2 | Stereo pair 3 | left | 5 |
| | | right | 6 |
| | Stereo pair 4 | left | 7 |
| | | right | 8 |
| Group 3 | Stereo pair 5 | left | 9 |
| | | right | 10 |
| | Stereo pair 6 | left | 11 |
| | | right | 12 |
| Group 4 | Stereo pair 7 | left | 13 |
| | | right | 14 |
| | Stereo pair 8 | left | 15 |
| | | right | 16 |

In some cases there may only be two channels of audio associated with the video: Group1, Stereo Pair 1.

| HDMI Embedded Audio | | |
|----------------------------|----------------|---------------|
| Stereo Pair | Channel | Number |
| Stereo pair 1 | left | 1 |
| | right | 2 |
| Stereo pair 2 | left | 3 |
| | right | 4 |
| Stereo pair 3 | left | 5 |
| | right | 6 |
| Stereo pair 4 | left | 7 |
| | right | 8 |

13. Calibrating the T-bar

After a firmware update of the switcher it will be necessary to re-calibrate the T-Bar to get it working correctly.

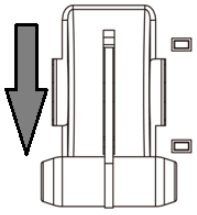

1. Move the **T-Bar** to its **lowest position**.

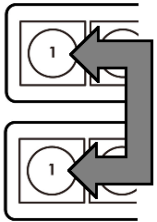

2. **Power OFF** the SE-2800 switcher.

3. Press and **hold down button 1** on both the **Program and Preset** rows of the switcher's keyboard.

4. **Power ON** the SE-2800 switcher while **still holding down the buttons** in step 3.

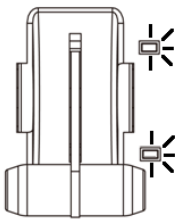

5. The switcher will start but the keyboard lights will remain dead except for the T-Bar progress LEDs. When these **LEDs flash ON and OFF** release the buttons from step 3.

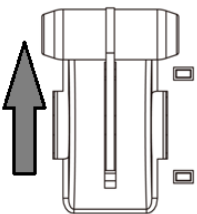

6. Move the **T-Bar to its top position** and then press the **CUT button**.

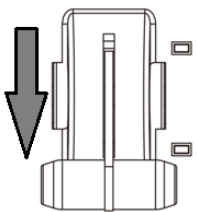

7. Move the **T-Bar back to its lowest position** and then press the **AUTO TAKE button**.



8. To exit the calibration procedure press the **CLOCK button**.

9. Ensure the **TIMER button** is **OFF**.

10. Test the T-Bar.

If necessary change the **T-Bar Mode** in the **OSD MENU options**.

14. LOGOS Setup

14.1 Static Logos

HS-2800 can store 7 static logos. SEConfig bookmark "Logos".

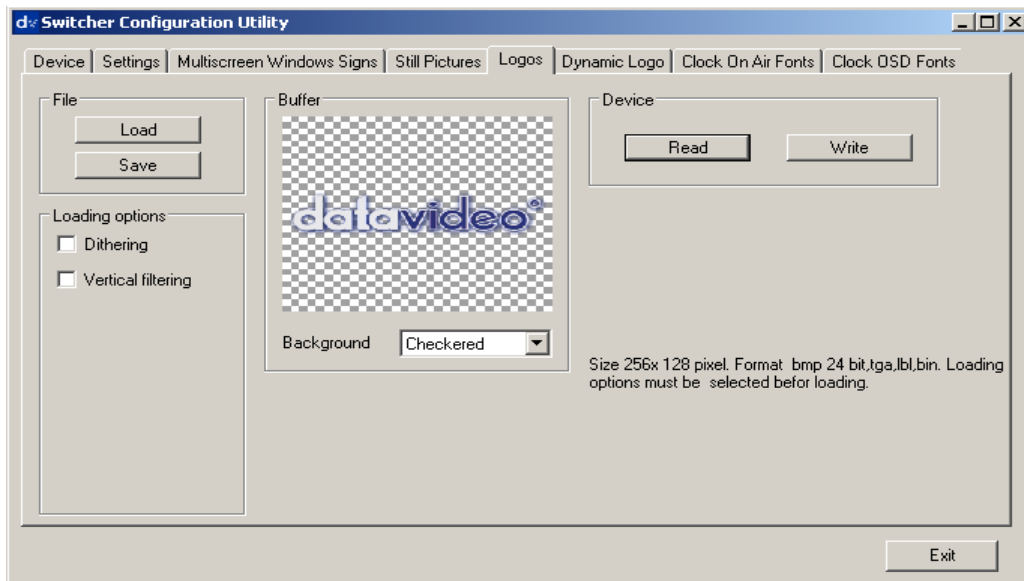

The static Logos to be loaded and written into 1 to 7 memory slots must be 256x128 pixels. This Logos must be created in a graphics software package first as:

- TGA 32bit with a clear Alpha Channel background.
- PNG 32bit with a clear Alpha Channel background.
- GIF. Indexed color 8 bit with a transparent background but without translucent shadow.
- BMP 24bit file - without a transparent background. It is possible to use the pair of BMP files for clear Alpha Channel BG added by SEConfig: The first file - Logo with Black background named as xxx.bmp , the second - Logo with white background named as xxx_w.bmp. The SEConfig accept this pair as one picture.
- JPG 24bit file - without a transparent background.

It can be possible to save logos in the own SEConfig format lbl or bin and Load it by SEConfig

14.2 Dynamic Logo

SE -2800 can store 1 dynamic logo. SEConfig bookmark "Dynamic Logo".

This Logo needs to be created in a graphics software package first as a sequence of up to 75 image. Image size must be 256 x 128 pix, 8 bits/channel

Format is the same as for Static Logos:

- TGA 8 bit/channel - with a clear Alpha Channel background.
- PNG 8 bit/channel - with a clear Alpha Channel background.
- GIF Indexed color 8 bit with a transparent background but without translucent shadow.
- BMP 8 bit/channel file - without a transparent background. It is possible to use the pair of BMP files for clear Alpha Channel BG added by SEConfig: The first file - Logo with Black background named as xxx.bmp, the second - Logo with white t background named as xxx_w.bmp. The SEConfig accept this pair as one picture.

- JPG 24bit file - without a transparent background. And supplementary:
- AVI
- Animated GIF

Dynamic Logos' picture display sequence is determined by the number in the name (Note: for the correct sorting, the number in the name must have 2 digits: 01. 02 ... 09, 10...).

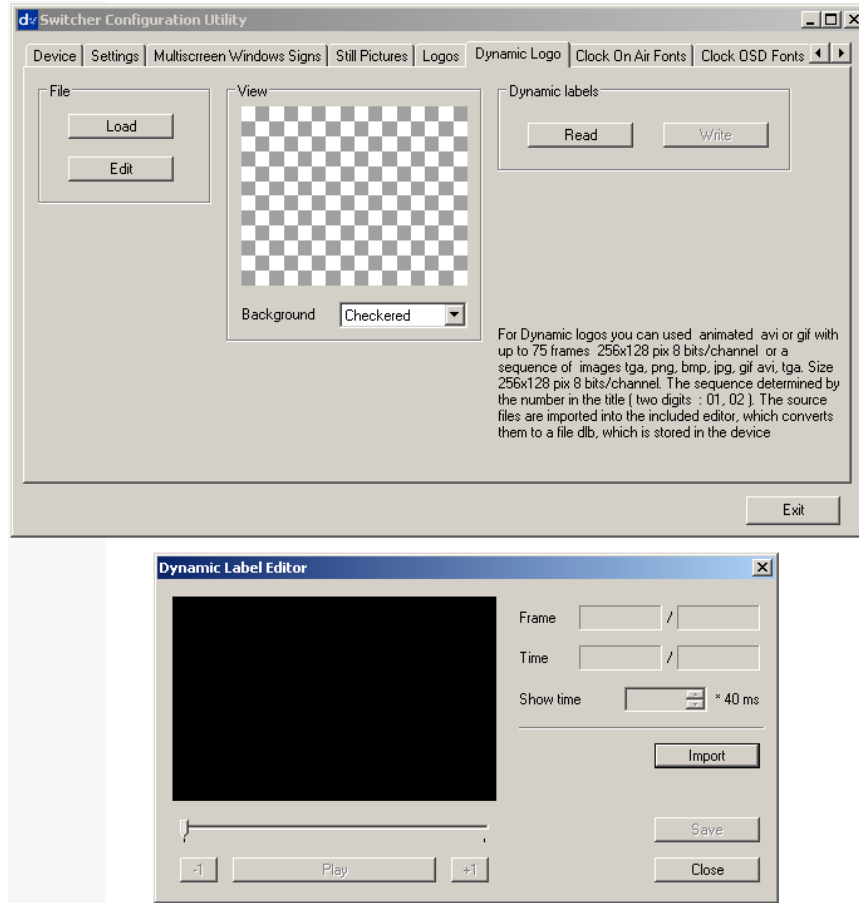

The source files must be imported into the included editor: Button Edit", then button "Import" Each frame can have its own "Show time" (40ms step).

The button "Play" can show preview - if everything is fine; the new Dynamic Logo must be saved as xxx.dlb file which can be stored in the device: button "Load" (select xxx.dlb) and then button "Write" - write to Slot1.

15. Tally Connector PIN Assignment

The output signals from the tally output pins are for lighting the tally lamps, and these outputs are open collector outputs.

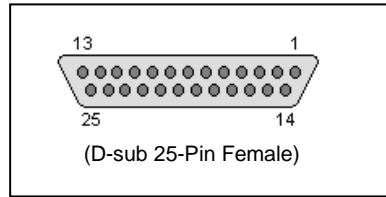

PIN Assignment

| Pin No. | Signal name | Input/Output | Description of signal |
|---------|-------------|-----------------------|--|
| 1 | Program 1 | Open collector output | Tally output of input video Program 1 |
| 2 | Program 2 | Open collector output | Tally output of input video Program 2 |
| 3 | Program 3 | Open collector output | Tally output of input video Program 3 |
| 4 | Program 4 | Open collector output | Tally output of input video Program 4 |
| 5 | Program 5 | Open collector output | Tally output of input video Program 5 |
| 6 | Program 6 | Open collector output | Tally output of input video Program 6 |
| 7 | Program 7 | Open collector output | Tally output of input video Program 7 |
| 8 | Program 8 | Open collector output | Tally output of input video Program 8 |
| 9 | Program 9 | Open collector output | Tally output of input video Program 9 |
| 10 | Program 10 | Open collector output | Tally output of input video Program 10 |
| 11 | Program 11 | Open collector output | Tally output of input video Program 11 |
| 12 | Program 12 | Open collector output | Tally output of input video Program 12 |
| 13 | GND | Ground | Ground |
| 14 | Preset 1 | Open collector output | Tally output of input video Preset 1 |
| 15 | Preset 2 | Open collector output | Tally output of input video Preset 2 |
| 16 | Preset 3 | Open collector output | Tally output of input video Preset 3 |
| 17 | Preset 4 | Open collector output | Tally output of input video Preset 4 |
| 18 | Preset 5 | Open collector output | Tally output of input video Preset 5 |
| 19 | Preset 6 | Open collector output | Tally output of input video Preset 6 |
| 20 | Preset 7 | Open collector output | Tally output of input video Preset 7 |
| 21 | Preset 8 | Open collector output | Tally output of input video Preset 8 |
| 22 | Preset 9 | Open collector output | Tally output of input video Preset 9 |
| 23 | Preset 10 | Open collector output | Tally output of input video Preset 10 |
| 24 | Preset 11 | Open collector output | Tally output of input video Preset 11 |
| 25 | Preset 12 | Open collector output | Tally output of input video Preset 12 |

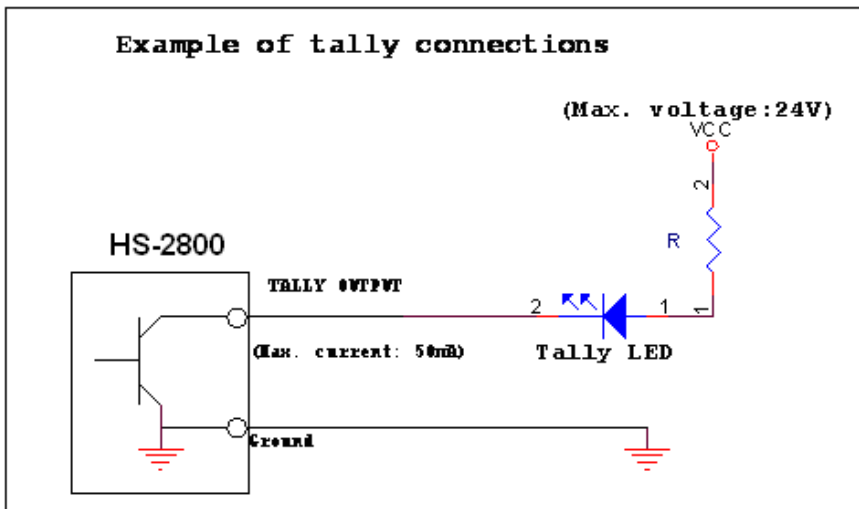

Pin 1 to 25 must satisfy the following conditions:

Dielectric strength: Max. DC 24V
 Current: Max. 50Ma

16. Audio Delay

From firmware version 3.80 onwards, the SE-2800 and HS-2800 switchers now have a feature for Audio Delay up to 16 fields, or 8 frames. The audio delay is expressed in fields with a default setting of '02' (2 fields / 1 frame) on each input until you change it.

First you will need to confirm the firmware version number for your switcher.

1. Power on 2800 Switcher.
2. Press any arrow key under the designated Menu row.
3. Press the Right Arrow [▶] key to check your *Version Number*.

With your firmware updated to 3.80 or later, you can now follow the next steps to set up your Audio Delay.

16.1 Setting the Audio Delay

1. Power on 2800 Switcher.
2. On the Preview bus, select the input that you would like to set Audio Delay.
3. Press any arrow key under the designated Menu row.
4. Press the Down Arrow [▼] key until "Input Audio Settings" is selected.
5. Press the Right Arrow [▶] key to enter into the Input Audio Settings Menu.
6. Press the Right Arrow [▶] key to enter the Audio Delay Setting Menu.

The default setting is 02; which is measured in fields. 2 fields = 1 frame.

7. Use the Arrow keys to set the number of fields, or frames. You can set the delay from 1 to 16 fields, which is the equivalent of 1 to 8 frames.
8. When you have made your selection, press the Enter key
9. To Exit the Menu, press any key in the Program or Preview Bus.

* To set audio delay for all inputs: repeat the above steps for each individual input. Otherwise, the Audio Delay will remain at the default setting of 02.

17. GPI / GPO Connections

The SE-2800 can control external recorder/playback devices like the HDR-45 and HDR-55 via a simple contact closure GPI / GPO switch.

The GPI interface is a 3.5mm Jack Socket which is situated on the rear panel of the SE-2800. Contact closure between the Outer and Inner contacts on the jack plug will trigger a user selected event. Power is supplied by the SE-2800 and is less than 5V DC.

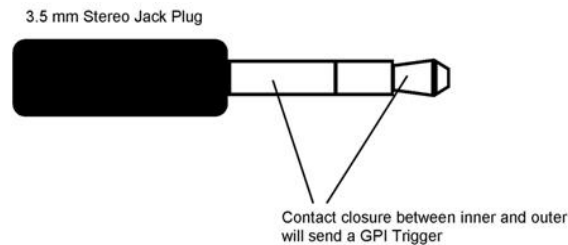

This GPI socket can also be used as a GPO socket to trigger record or playback events with other equipment such as the Datavideo HDR-70 recorder.

SAFETY FIRST The cabling required needs to be designed specifically to connect the SE-2800 to the chosen record or playback device as they are not all the same. The cabling required can be made by yourself or a competent technician. Please speak with your Dealer or local Datavideo office to get further help and advice.

18. Specifications

18.1 HS-2800 Specifications

| | |
|--------------------------------|---|
| Inputs | 8 inputs, can be configurable to HD SDI, 8 SD SDI, 2 HDMI |
| Outputs | 2 BNC output connectors for SDI Outputs 1 HDMI for Multi-screen (v.1.1) RJ-45 for PC Remote controls 2 BNC for Sync-In and Sync-Out |
| Video Input | HD/SDI: 1920 x 1080i/50, 1920 x 1080i/60, 1920 x 1080i/59.94 SD: PAL 720 x 576 /50Hz SD: NTSC 720 x 480 /59.9Hz HDMI 1920 x 1080i/50 HDMI 1920 x 1080i/59.94 HDMI 1920x1080i/60Hz HDMI 720 x 576i/50Hz HDMI 720x480i/60Hz Y:Cb:Cr, 4:2:2 10 bit |
| Preview Outputs | 1x HDMI output Way 1: 8 smaller windows for inputs 1-8 with embedded audio level indication (group1, channel 1,2) Way 2: HDMI 1 Multiscreen1- 8 smaller windows for inputs 1-8 with embedded audio level indication (group1, channel 1,2) + 2 bigger windows for Preview and Program with embedded audio level indication on Program (group1, channel 1,2) Resolution is 1920x1080i |
| Other Interface | Serial D-Sub 9 Pin x 1 RS232 Tally Output D-Sub 25 Pin x 8 Channel Open Collector Output Support Line mode (Analog Audio) GPI port |
| HD SDI signal | SMPTE 292M standard complied with Output return loss : More than 15 dB (270MHz) More than 10 dB (1.5 GHz) Output level : 0.8 Vpp ± 10% Rise time : Less than 270 ps Fall time : Less than 270 ps Difference between rise time and fall time is within 100 ps Alignment jitter : Less than 0.2 UI Timing jitter : Less than 1.0 UI DC offset : 0 ± 0.5V Equalizer uses 5C-FB cable supporting 100 meters |
| Operating Temperature | 0°C to 40°C (32°F to 102°F) |
| Humidity | 10% to 90% (non condensing) |
| Dimensions & Weight | 455mm (W) x 140.5mm (H) x 358mm (D) = 8.7 Kg (19.18 lbs) |
| Power | 12V / 80W |

18.2 ITC-150 (Intercom) Specifications

| | | |
|--------------------------------|----------------------|---|
| INPUTS & OUTPUTS | MIC / HEADSET | 3.5mm Stereo Jack Socket for Headphone / Microphone combination Headset Impedance 8~600 ohms 100mW (min) |
| | HEADPHONE | ¼" (6.3mm) Stereo Headphone Socket Headset Impedance 8~600 ohms 100mW (min) |
| | MICROPHONE | 3 Pin XLR / ¼" (6.3mm) Jack Microphone Socket Switchable Condenser / Dynamic Input. Microphone Sensitivity Level : -67dB |
| Communication interface | | 8 channels 5 pin XLR |
| FREQUENCY RESPONSE | | 550-3.6KHz, < +/-3dB |
| THD | | < 3% |
| S/N | | > 50dB |
| BUILT-IN SPEAKER | | 70mm x 30mm 32 Ohm 3 Watts |

18.3 ITC-100SL Specifications

| | |
|-----------------------------|--|
| INPUT | 5 Pin XLR Connector |
| MIC / HEADSET SOCKET | 3.5mm Stereo Jack Socket for Headphone / Microphone combination Headset Impedance 8~600 ohms 100mW (min) Microphone Level -67dB or 2.5mm Stereo Jack Socket, for Motorola Mobile Phone type headset / microphone |
| TALLY OUT SOCKET | 3.5mm Jack Socket to connect to TD-1 Tally Indicator |
| TALLY LED | Bi-Colour LED – RED indicates LIVE / AMBER Indicates CUED |
| POWER LED | Illuminates to indicate that power is ON |

18.4 TLM-170H Specifications

| | |
|-------------------------------|--|
| LCD Display | 17.3" TFT LCD |
| Resolution | RGB 1600 x 900 pixel |
| Aspect Ratio | 4:3 and 16:9 selectable |
| LED Life time | 12,000 hrs. (approx.) |
| Brightness (Luminance) | 220 cd/m ² |
| Contrast Ratio | 500:1 |
| View Angle | Top: 40 deg Bottom: 60 deg Left: 60 deg Right: 60 deg |
| Video System | NTSC / PAL auto detection |
| Colour Adjustment | Brightness, Contrast, Colour Saturation |
| Operating condition | Operating temperature from 0°C to 50°C, RH less than 90% |

Service & Support

It is our goal to make owning and using Datavideo products a satisfying experience. Our support staff is available to assist you to set up and operate your system. Contact your local office for specific support requests. Plus, please visit www.datavideo.com to access our FAQ section.

Datavideo USA

Datavideo Corporation
7048 Elmer Avenue.
Whittier, CA 90602,
U.S.A.
Tel: +1-562-696 2324
Fax: +1-562-698 6930
E-mail: sales@datavideo.us

Datavideo The Netherland

Datavideo Technologies Europe BV
Floridadreef 106
3565 AM Utrecht,
The Netherlands
Tel: +31-30-261-96-56
Fax: +31-30-261-96-57
E-mail: info@datavideo.nl

Datavideo United Kingdom

Datavideo UK Limited
Units1 & 2 Waterside Business Park
Hadfield, Glossop, Derbyshire
SK13 1BE, UK
Tel: +44-1457 851 000
Fax: +44-1457 850 964
E-mail: sales@datavideo.co.uk

Datavideo Taiwan

Datavideo Technologies Co. Ltd
10F. No. 176, Jian 1st Rd., Chung Ho
District, New Taipei City 235, Taiwan,
R.O.C.
Tel: +886-2-8227-2888
Fax: +886-2-8227-2777
E-mail: service@datavideo.com.tw

Datavideo China

Datavideo Technologies China Co
101, NO.618, LiuYing Rd, Zhabei District,
Shanghai, China
Tel: +86 21-5603 6599
Fax: +86 21-5603 6770
E-mail: service@datavideo.cn

Datavideo Singapore

Datavideo Technologies (S) PTE Ltd
No. 178 Paya Lebar Road #06-03
Singapore 409030
Tel: +65-6749 6866
Fax: +65-6749 3266
E-mail: sales@datavideo.sg

Datavideo Hong Kong

Datavideo Hong Kong Ltd
G/F., 26 Cross Lane
Wanchai, Hong Kong
Tel: +852-2833-1981
Fax: +852-2833-9916
E-mail: info@datavideo.com.hk

Datavideo France

Datavideo France s.a.r.l
Cité Descartes 1, rue Albert Einstein
Champs sur Marne
774477-Marne la Vallée cedex 2
Tel: +33-1-60370246
E-mail: info@datavideo.fr

Datavideo India

Datavideo Technologies India Pvt Ltd
A-132, Sec-63, Noida-201307,
Uttar Pradesh (UP), India.
Tel: +91-0120-2427337
Fax: +91-0120-2427338
E-mail: sales@datavideo.in



Please refer to our website for update the latest version manual.
www.datavideo.info/Mobile+Studios/HS-2800

datavideo[®]
www.datavideo.com